

# B&R Servo Drive

## ACOPOS MULTI

Plug-in Module: **ENDAT 8BAC0120.000-1**

Figure	X11	Pin	Name	Function
		1	A	Channel A
		2	COM	Encoder supply 0 V
		3	B	Channel B
		4	+5V	Encoder supply +5 V
		5	D	Data input
		6	---	---
		7	T+	Temperature sensor +
		8	T	Clock output
		9	A\	Channel A inverted
		10	Sense COM	Sense input 0 V
		11	B\	Channel B inverted
		12	Sense +5V	Sense input +5 V
		13	D\	Data input inverted
		14	T-	Temperature sensor -
		15	T\	Clock output inverted

Table: Pin assignments - EnDat 2.1 interface 8BAC0120.000-1

Plug-in Module: **SIN/COS 8BAC0124.000-1**

Figure	X11	Pin	Name	Function
		1	A	Channel A
		2	COM	Encoder supply 0 V
		3	B	Channel B
		4	+5V	Encoder supply +5 V
		5	T+	Temperature sensor +
		6	Limit -	Negative limit (L2)
		7	R\	Reference pulse inverted
		8	Limit+	Positive limit (L1)
		9	A\	Channel A inverted
		10	Sense COM	Sense input 0 V
		11	B\	Channel B inverted
		12	Sense +5V	Sense input +5 V
		13	T-	Temperature sensor -
		14	R	Reference pulse
		15	---	---

Table: Pin assignments - SinCos interface 8BAC0124.000-1

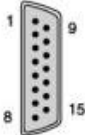
## Acopos

Plug-in Module: **8AC120.60-1**

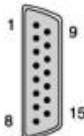
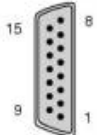

Figure	X11	Pin	Name	Function	
				EnDat mode	Incremental mode
		1	A	Channel A	
		2	COM (1, 3 - 9, 11, 13 - 15)	Encoder supply 0 V	
		3	B	Channel B	
		4	+5V out / 0.25A	Encoder supply +5 V	
		5	D	Data input	---
		6	---	---	
		7	R\	---	Reference pulse Inverted
		8	T	Clock output	---
		9	A\	Channel A inverted	
		10	Sense COM	Sense input 0 V	
		11	B\	Channel B inverted	
		12	Sense +5V	Sense input +5 V	
		13	D\	Data Inverted	---
		14	R	---	Reference pulse
		15	T\	Clock output Inverted	---

Table: Pin assignments for AC120 - EnDat Encoder Interface

## Acopos P3

Plug-in Module: **8EAC0152.001-1**

Figure	X41M	Pin	Name	Function depending on configured encoder type			
				SinCos	EnDat 2.1	SSI SinCos	HIPERFACE
		1	B\	Channel B inverted			REF cosine
		2	B	Channel B			Cosine
		3	GND	Encoder power supply 0 V			
		4	A\	Channel A inverted			REF sine
		5	A	Channel A			Sine
		6	R	Reference pulse	Data +		
		7	R\	Reference pulse inverted	Data -		
		8	U+	Encoder power supply 5 V			Encoder power supply 12 V
		9	T-	Temperature sensor -	Clock -		Temperature sensor -
		10	T+	Temperature sensor +	Clock +		Temperature sensor +

## Encoder configuration

Incremental encoder (nclNC) with **ParID 109** = 16384 (Intrpolation factor)

## Motor phases

V and W phase inverted.

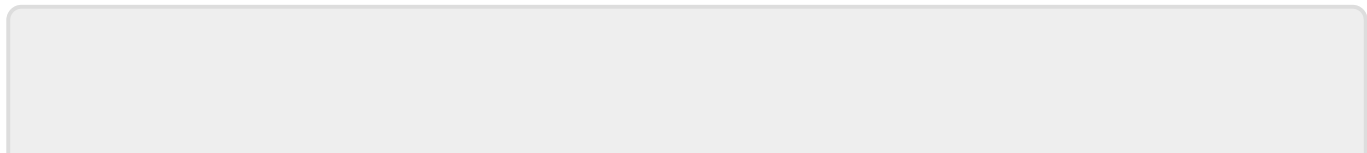

From:  
<https://dokuwiki.nilab.at/> - **NiLAB GmbH**  
**Knowledgebase**

Permanent link:  
[https://dokuwiki.nilab.at/doku.php?id=green\\_drive\\_iso:b\\_r\\_drive](https://dokuwiki.nilab.at/doku.php?id=green_drive_iso:b_r_drive)

Last update: **2026/02/10 15:45**

