

# Installation procedure

## How to mount the rod inside the motor

The slider of the motor is provided in a separate carton tube to avoid damage during transportation. This slider has a end stop without threaded holes (male or female) on the closed side.



In order to install, the customer must be open the open side, the grub screws must be unscrewed.



Dismount completely the end cap



Then, insert the slider inside the motor

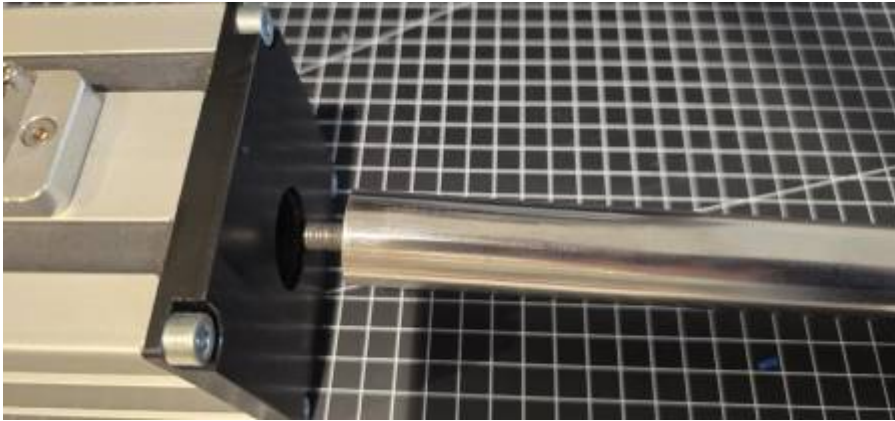

Mount again the end stop on the internal screw of the slider

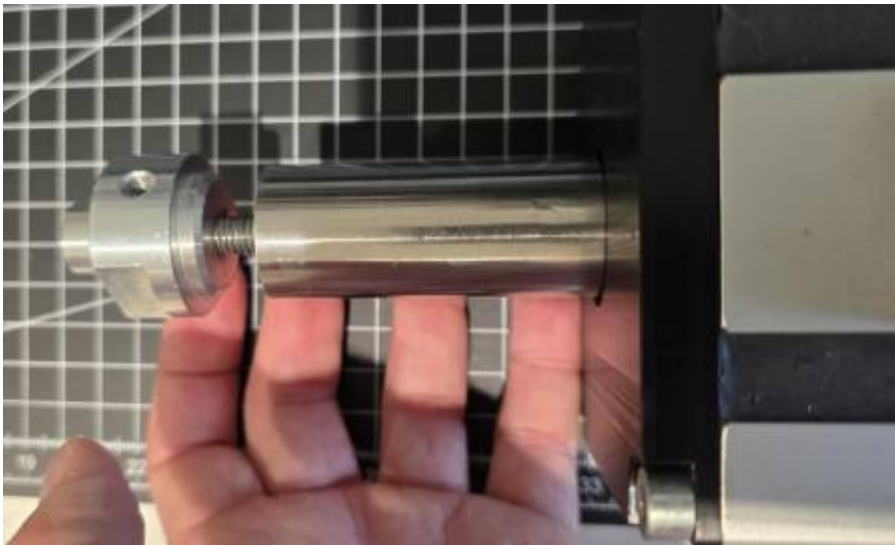

Close completely the end cap reaching the stainless steel rod end.



Screw the grub screws to avoid the end cap rotation.

## Interaction with the load

The slider motion is based on polymer plain bearings, the motor slider can only sustain limited radial loads; it is therefore required to support the payload through a proper linear guide. Moreover, coupling the shaft with the payload by spherical bearings, articulated joints or equivalent parts is recommended in order to only transmit the linear thrust and to compensate any radial misalignment.

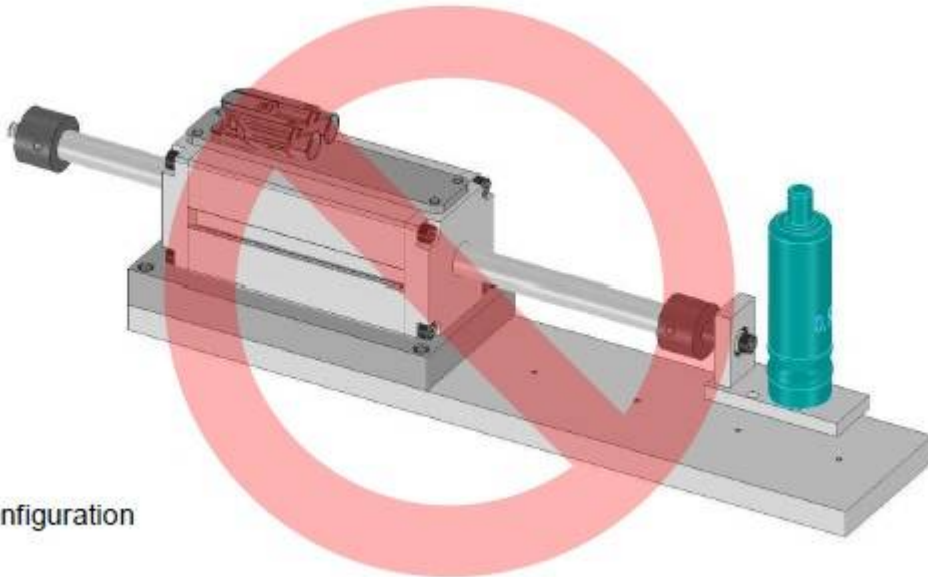

Wrong configuration

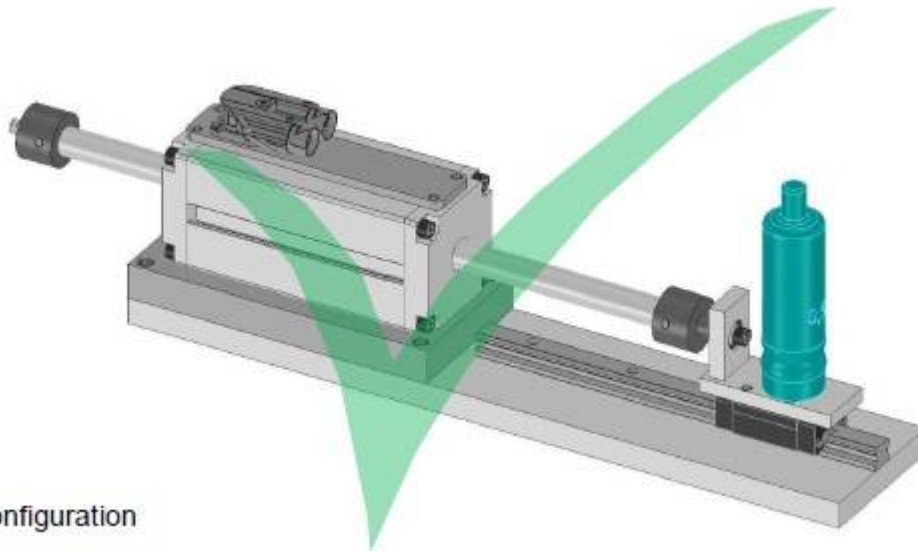

Correct configuration

## Magnetic fields

The slider of the green drive linear motor is fitted with strong permanent magnets, which are not magnetic shielded ( $B_r \approx 1.2 \text{ T}$ ). However, the magnetic induction collapses within 50 mm so there is no considerable field outside the machine structure.

## Vibrations and shocks

The stator of Green Drive series tubular linear motors can sustain shocks up to 5 G (49 m/s<sup>2</sup>) and vibrations up to 2,5 G (24,5 m/s<sup>2</sup>).

## Noise emission

The noise emission of synchronous linear drives can be compared with conventional inverter-operated feed drives. Experience has shown that the noise generation mainly depends on

- the employed linear guides (velocity-related travel noise),
- the mechanical design (following cover, etc.), and
- the settings of drive and controller (e.g. switching frequency).

A generally valid specification is therefore not possible.

From:

<https://dokuwiki.nilab.at/> - **NiLAB GmbH**  
**Knowledgebase**

Permanent link:

[https://dokuwiki.nilab.at/doku.php?id=green\\_drive\\_motors:installation](https://dokuwiki.nilab.at/doku.php?id=green_drive_motors:installation)

Last update: **2025/09/30 11:34**

