

Analog control

For analog control, the NLi integrated linear motor can be equipped with an additional M12 connector. See connection system

pinout:https://www.nilab.at/dokuwiki/doku.php?id=integrated_drive_motors:connection_system

Analog current (4 to 20 mA)

The Servo Cylinder's motion controller is fully closed loop, but many industrial processes and systems require direct position feedback to close the loop on their processes or to control a larger system. For these cases, NLi models are available with man analog current input feature. This can be used with analog current signal (4-20 mA) proportional to position, force, velocity.

In this case of position control 4mA correspond to 0mm position and 20mA to the maximum stroke of the motor. Input resistance here is 150 ohm, corresponding to a internal voltage of 3V.

Using NiLAB Starter software the user can set the scale, offset and mode of this control.

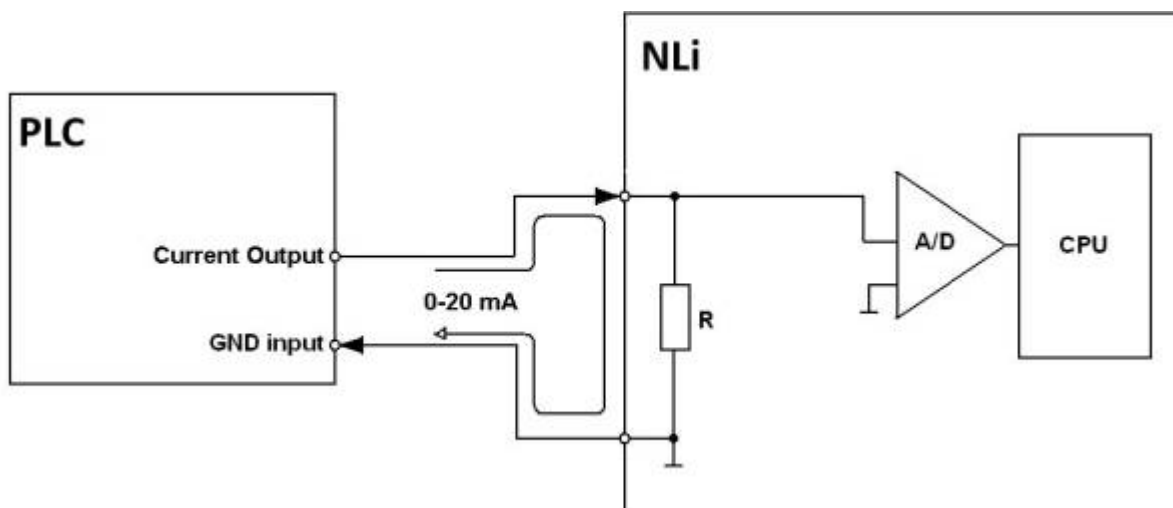

Voltage control (0 to 10V)

Voltage control can be used for position, force and velocity control as the Analog current control.

Using NiLAB Starter software the user can set the scale, offset and mode of this control.

From:

<https://dokuwiki.nilab.at/> - NiLAB GmbH
Knowledgebase

Permanent link:

https://dokuwiki.nilab.at/doku.php?id=integrated_drive_motors:analog_control

Last update: 2024/07/31 06:54



