

Liquid Cooled Motors (LK)

Liquid cooled motors must have a proper closed loop cooling circuit. The cooling medium has to be composed from desalted and demineralized water chemically neutral and with the addition of anti-corrosion agent. Such products must be compatible with all the components of the circuit.

	<p>Do not connect the cooling system to a regular water line!</p> <p>Using regular, untreated water can cause severe damage to the cooling system and it is to be avoided in any circumstance.</p>
---	---

Operating conditions

Please check and respect the following recommendation:

- Maximal water inlet pressure (< 1 min) $P_{max} = 1 \text{ MPa}$, **$P_{max} = 10 \text{ Bar}$** .
- Rated water inlet pressure $P_n = 0,5 \text{ MP}$, **5 Bar max.**
- Minimal water flow and minimal pressure drop: listed in the catalogue or relevant datasheet (varies according to motor, size)
- PH-value: 6,5 to 7,5 without aggressive additives.
- Rated water inlet temperature $T_n = 20^\circ\text{C}$ to 40°C
- Water quality: The recommended water hardness is 0,7 mmol/l (= 4°dH) water hardness / filtered, no solid particles.
- If cooling water does not meet this parameter, plasticizers should be used.

Water type

The use of inhibitors to prevent corrosion in aluminum is strongly recommended. The ratio of anticorrosive agent (25%) to water (75%) should not be exceeded, otherwise a reduction in performance may occur.

Alternatively, other coolant can be used, such as water-glycol antifreeze, various coolant oils, etc. In this case, however, reduced performance is to be expected. The specific derating is determined by calculation after consultation with the manufacturer.

A constant monitoring of cooler flow is recommended: We recommend the usage of a detector for the water pressure and the rate of water flow in order to prevent the unlike event of an emergency shut down of the machine due to an overheated servo motor.

Inlet cooling media temperature must be between 5° and 25°C to avoid condensation inside of the motor; in any case the inlet coolant temperature must be higher than the motor frame temperature of at least 2°C

Before activating the motor, make sure the cooling circuit is completely filled and leak free.

The whole water cooling circuit should be examined whether there are materials which are in touch with the cooling liquid and

A) have a certain voltage drop according to the electro-chemical voltage order and

B) are electrically connected so that an electro-galvanizing process can take place. In this case the noble metal will be destroyed and enriched at the more noble metal.

	<p>Risk of damage!</p> <p>Note that connection to the cooling circuit must be provided with use of flexible hosing. Otherwise there is a risk of motor damage. Take extra care when handling with liquid cooled motors. Careless handling can easily cause damage of the connection fitting.</p> <p>When connecting the linear motor to the external cooling system a spanner of appropriate size must be used to support the linear motor inlet and outlet fitting connection (see Figure below). Failure to do so may result in the cooling system leakage or in a complete failure of the linear motor!</p>
---	--

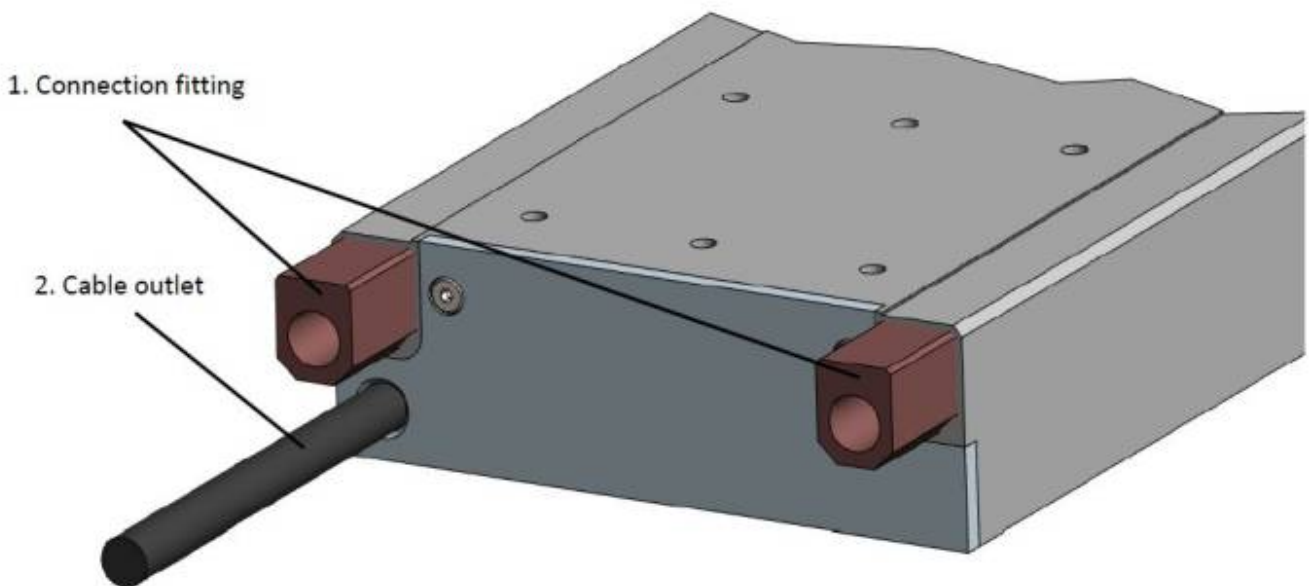

Active examples:

General use ⇒ Antifrogen N, [Datasheet](#)

Food application ⇒ Antifrogen L, [Datasheet](#)

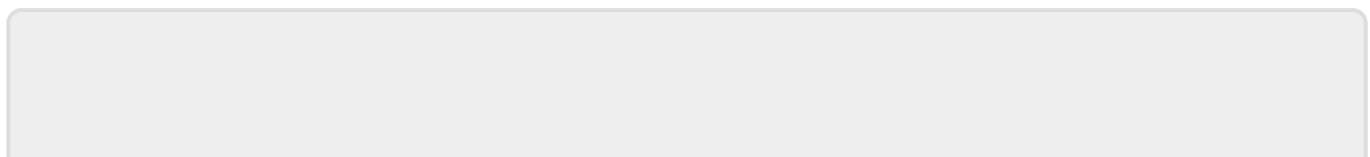

From:

<https://dokuwiki.nilab.at/> - **NiLAB GmbH**
Knowledgebase

Permanent link:

https://dokuwiki.nilab.at/doku.php?id=ironcore_motors:liquid_cooled

Last update: **2024/07/22 06:46**

