

Mounting example

1: Mount and secure the customer interface (1) on the motor (2) with the fixing screws (3).

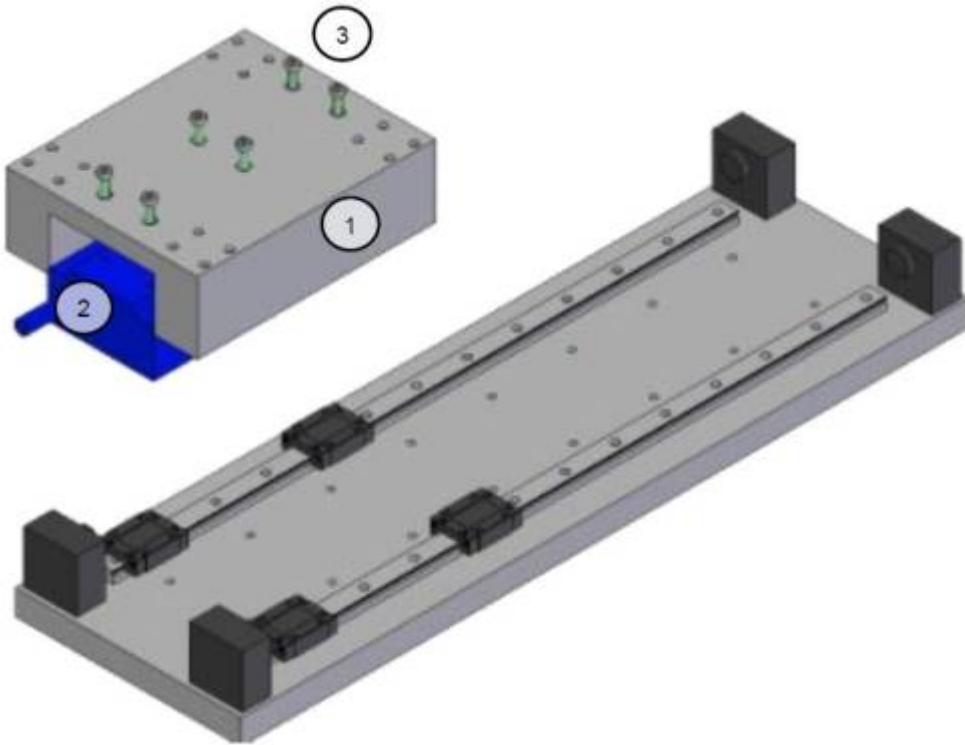

2: Mount and secure the magnetic way segments (4) on the baseplate with the fixing screws (5). The segments must be oriented with the north pole in the same direction; the position of the north pole is indicated on the name plate with N.

Warning: pay attention to the attraction forces between the magnetic way and the linear guides. Bring the magnetic way from the top and parallel to the baseplate.

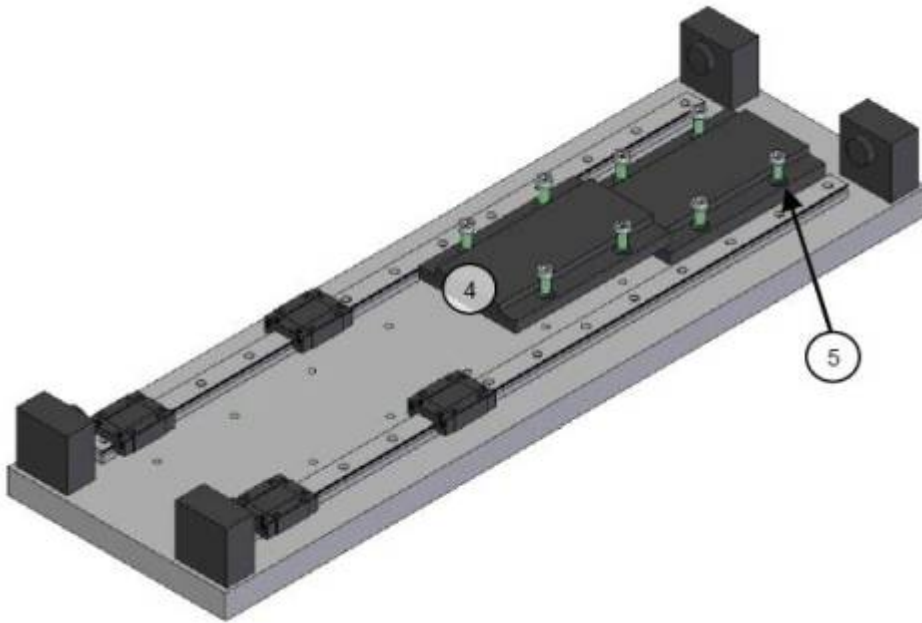

3: Mount and secure the motor assembly (6) on the linear guides (7).

Warning: pay attention to leave a minimum gap of 5 cm between the magnetic way and the motor assembly in order to avoid unintentional movement of the motor assembly.

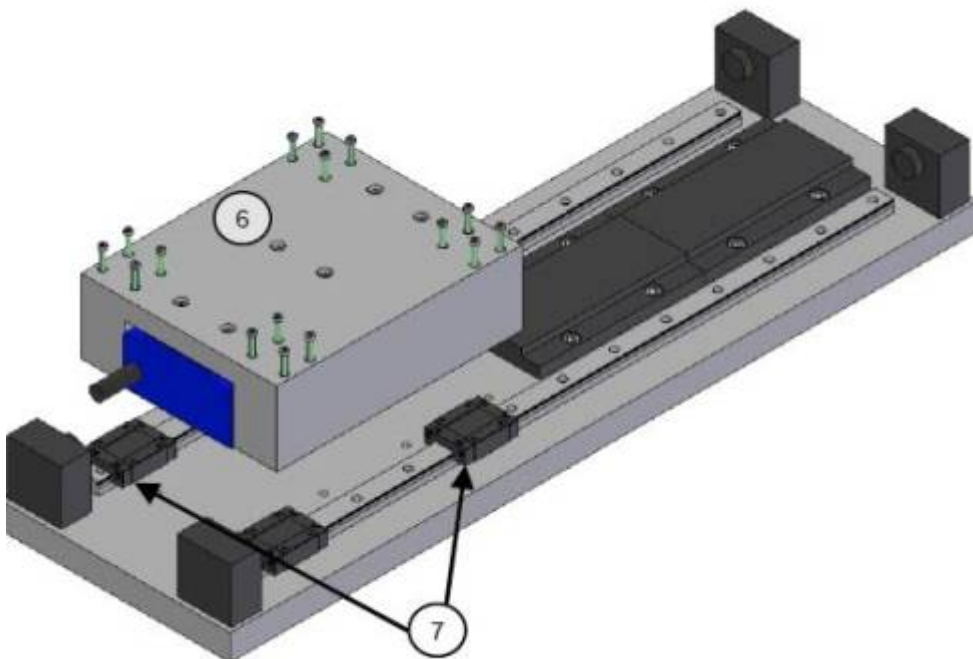

4: Slide the motor assembly (8) over the mounted magnetic ways and temporarily secure the motor against the mechanical end stop.

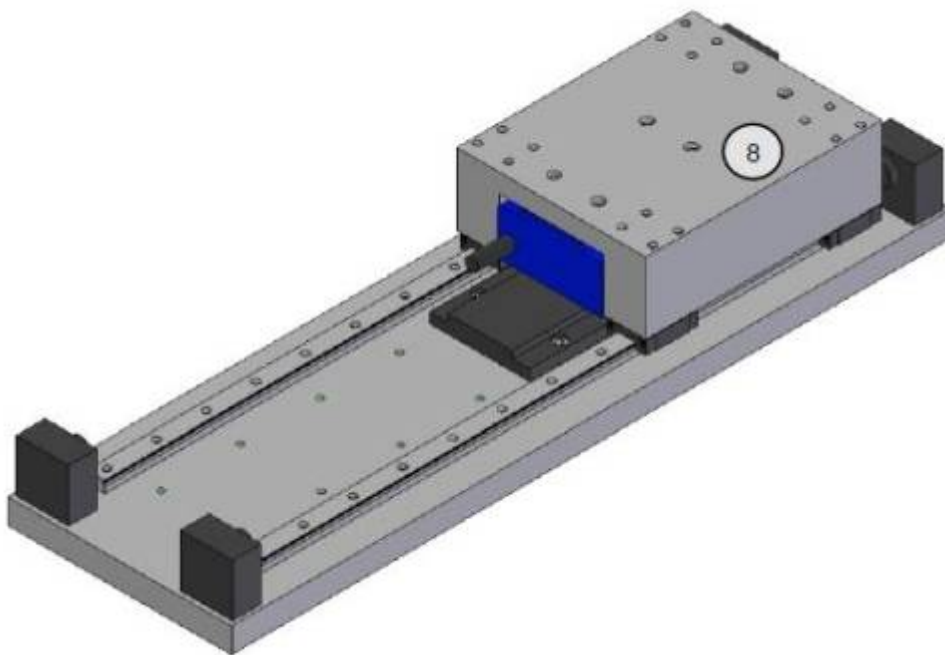

5: Mount and secure the remaining magnetic way segments (9) with the fixing screws (10). The segments must be oriented with the north pole in the same direction; the position of the north pole is indicated on the name plate with N.

6: Test whether the motor moves without contact with the magnetic ways over the entire stroke. It is normal to observe variations in the forces depending on the position (detent force).

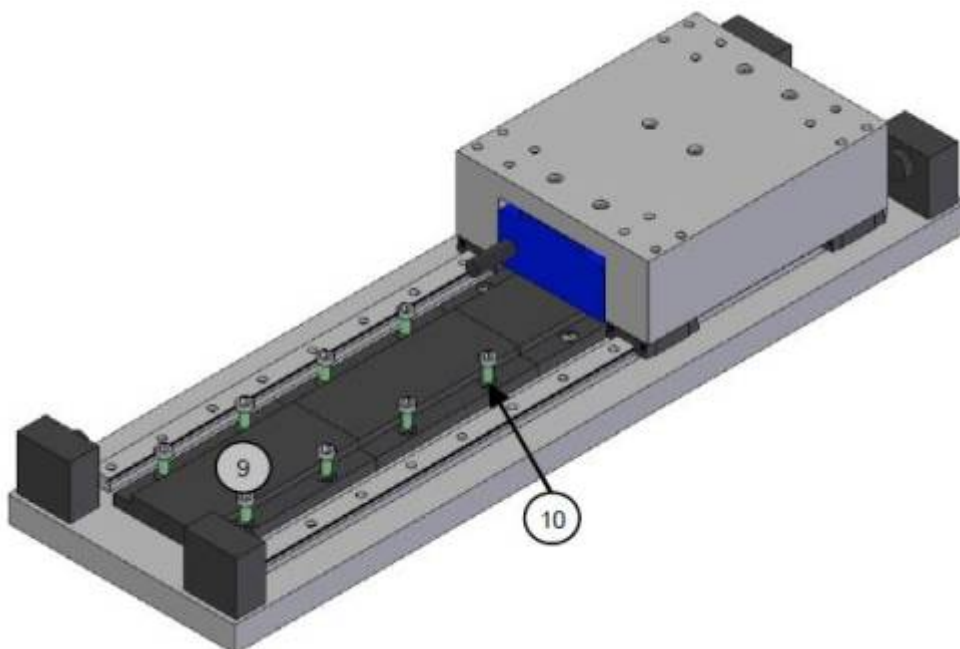

Orientation of the secondary parts and of the primary part

In a configuration with segmented secondary parts, the segments shall be mounted all with the same polarity, so with the north pole (marked with N) in the same direction. Therefore the N mark of each segment will be matching the S mark of the next one.

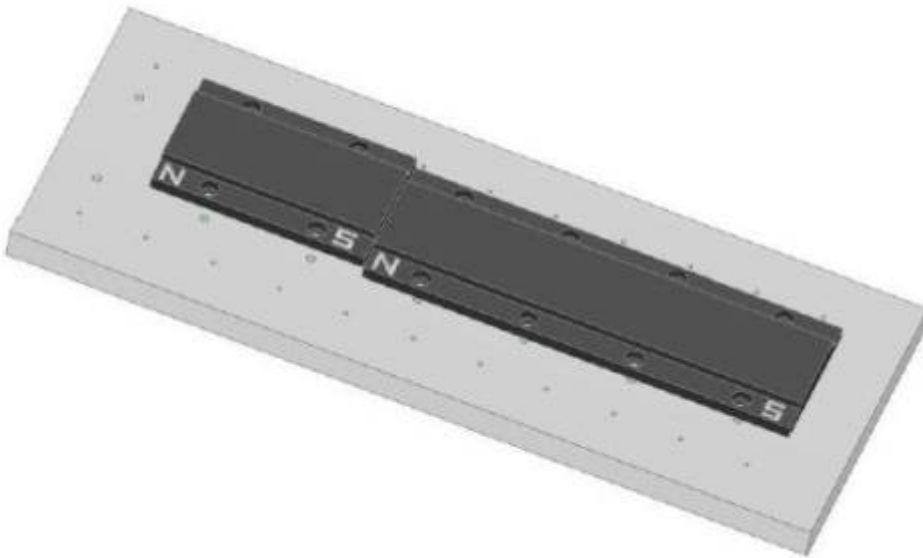

Then the primary part will be set up with the cables coming out towards the north pole of the secondary part. Otherwise, the motor phase sequence U, V, W will not be preserved.

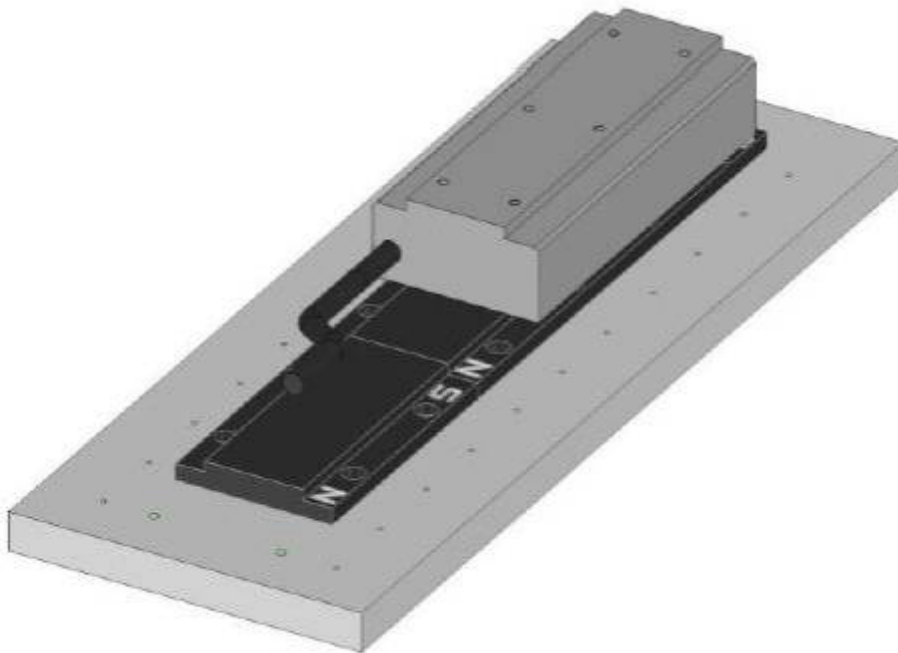

From:
<https://dokuwiki.nilab.at/> - NiLAB GmbH
Knowledgebase

Permanent link:
https://dokuwiki.nilab.at/doku.php?id=ironcore_motors:mounting

Last update: **2023/09/21 07:15**

