

# Installation

## Slider distance for parallel drive mounting

When the application needs tandem parallel configuration of the integrated drive linear motor, the two or more actuators must be mounted guaranteeing the safety distance L3 to avoid the interaction between the magnetic sliders.

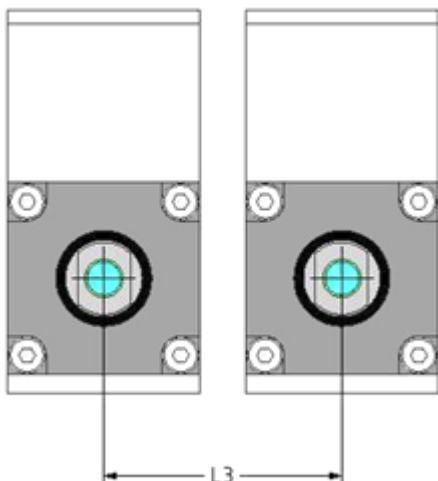

MOTOR MODEL	NO INTERACTION	MEDIUM INTERACTION	STRONG INTERACTION
NL040	> 20 mm	> 15 mm to 20 mm	< 10 mm
NL080	> 35 mm	> 15 mm to 35 mm	< 15 mm
NL120	> 65 mm	> 45 mm to 65 mm	< 45 mm

### NL040Q Fixing points

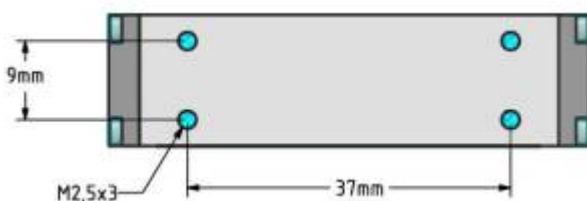

### NL040X Fixing points

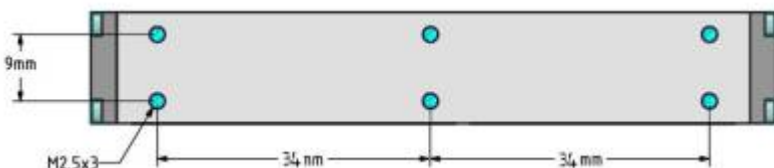

### NL080Q Fixing points

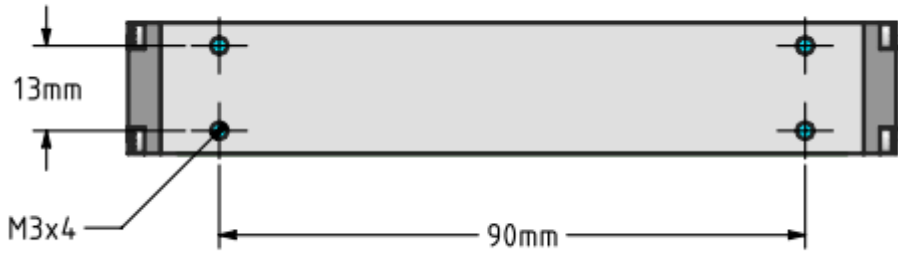

### NL080X Fixing points

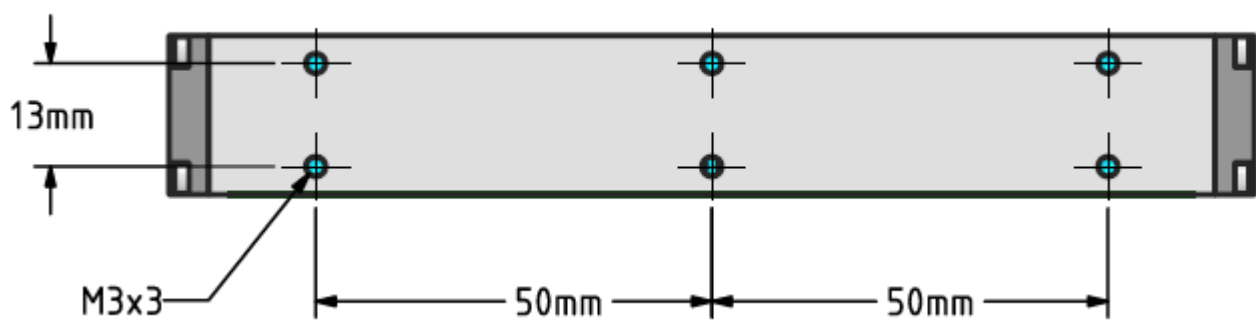

### NL120Q Fixing points

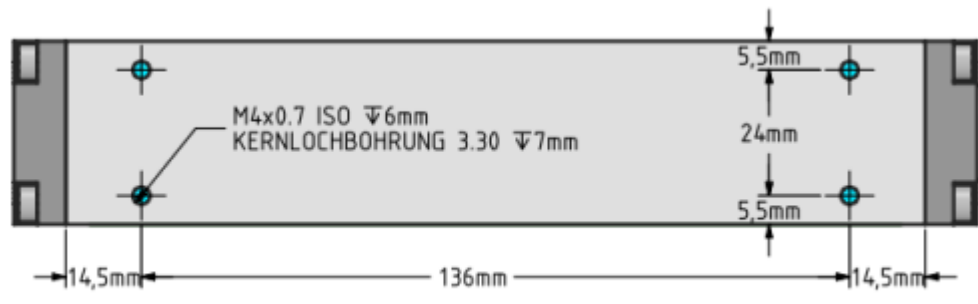

### NL120X Fixing points

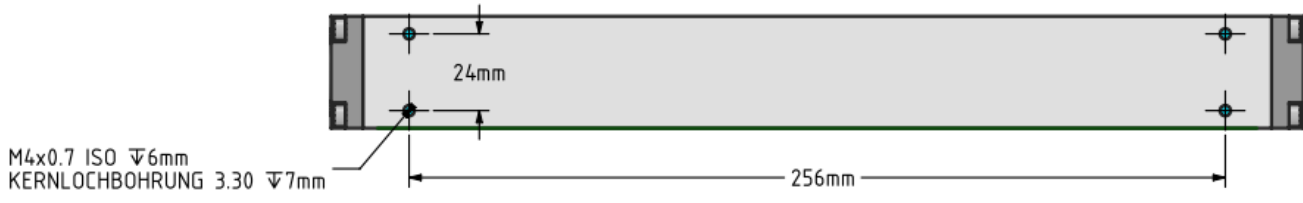

## NL040Q/X slider fixing point

Slider has M2 threaded hole at each slider ends.



## NL080Q/X slider fixing point

Slider has M4 threaded hole at each slider ends.



## NL120QX slider fixing point

Slider has M4 threaded hole at each slider ends.



From:

<https://dokuwiki.nilab.at/> - NiLAB GmbH  
Knowledgebase

Permanent link:

[https://dokuwiki.nilab.at/doku.php?id=miniature\\_motors:installation](https://dokuwiki.nilab.at/doku.php?id=miniature_motors:installation)

Last update: **2026/01/14 15:31**

