

# 13bit SIN/COS Encoder converter - Interpolator

## Overview

**NL-NQ6D** is an advanced interpolator for all kind of encoders with SIN/COS 1Vpp. This device with DIN rail mounting converts the SIN/COS 1Vpp analog signal into Quadrature Digital output AB with TTL 5V level output. Furthermore, it can also convert the SIN/COS 1Vpp analog signal into digital output BiSS-C or SSI. This is necessary when the servo-drive is not able to use directly the SIN/COS signal as feedback.



## Programming interface - Driver & Software

The interpolator can be programmed using programming cable DE23500555-1M in combination with programming software.

Programming cable windows driver can be downloaded here:

[:miniature\\_motors:usb\\_mb3u\\_driver\\_ftdi21224.zip](#)

The GUI interface can be downloaded here: [:miniature\\_motors:nqc\\_1so\\_gui\\_c8rte.zip](#)

## Features:

- 13 bit Interpolation with resolution up to 8192 angle steps per sine period.
- Binary and decimal resolution settings, e.g. 500, 512, 1000, 1024
- programmable angle hysteresis
- Conversion time of just 250 ns including amplifier settling
- Direct sensor connection; selectable input gain
- Input frequency of up to 250 kHz 6. Signal conditioning for offset, amplitude and phase
- A/B quadrature signals of up to 2 MHz with adjustable minimum transition distance
- Zero signal processing, adjustable in index position and width
- Absolute angle output via fast serial interface (BiSS, SSI)
- Permanent bidirectional memory access to parameters and OEM data by BiSS C
- Period counting with up to 24 bits
- Error monitoring of frequency, amplitude and configuration
- Device setup from serial EEPROM or using BiSS
- ESD protection and TTL-/CMOS-compatible outputs
- Ideal for all type of NiLAB Linear motors

The product is based on IC-Haus integrated circuits, please see datasheet for the full information:  
[:green\\_drive\\_motors:nqc\\_datasheet\\_e2en.pdf](#)

## Connectors

**X1 connector is male d-sub 9, X2 connector is female d-sub9, X3 connector is female d-sub 15.**

### X1 Connector – Incremental Output AB

Pin	Signal	Description
1	A+	Positive A
2	A-	Negative A
3	B+	Positive B
4	B-	Negative B
6	5VDC	Power supply
7	GND	Ground

### X2 Connector – BISS-C Bus

Pin	Signal	Description
1	NC	-
2	MA+	Clock P
3	Ma-	Clock N
4	VDD	5V logic
5	MO-	Master data output N
6	GND	Ground
7	SL+	Device Data input P
8	SL-	Device Data output P
9	MO+	Master data output P

### X3 Connector – SIN/COS 1Vpp encoder input

Pin	Signal	Description
1	NC	-
2	NC	-
3	NC	-
4	+5VDC	Encoder power supply
5	0V	Ground
6	SIN+	Positive sine
7	COS+	Positive Cosine
8	NC	-
9	PE	Shield
10	NC	-
11	NC	-
12	NC	-
13	SIN-	Negative Sine
14	COS-	Negative Cosine
15	NC	-

## Power supply

## Using programming cable

When the programming cable is used the power supply for Interpolator and the connected SIN/COS encoder can be provided by USB (in this case check is the current will be enough for the correct ioperation) or with external 5V power supply connected on the power X1.

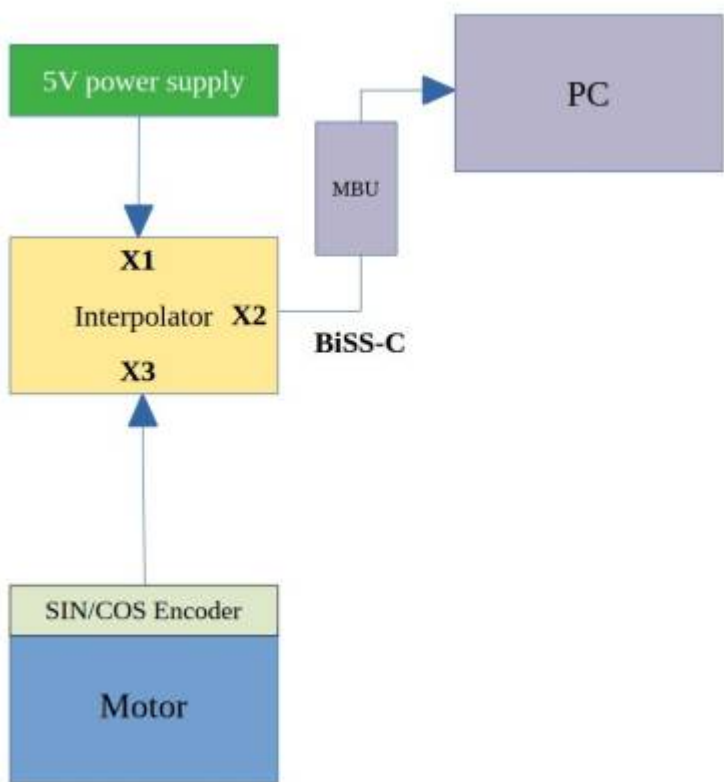

## Using Servo Drive

Connecting a servo drive BiSS interface, the 5V power can be provided by the feedback port of the servo drive or using external 5V power supply connected on port X1.

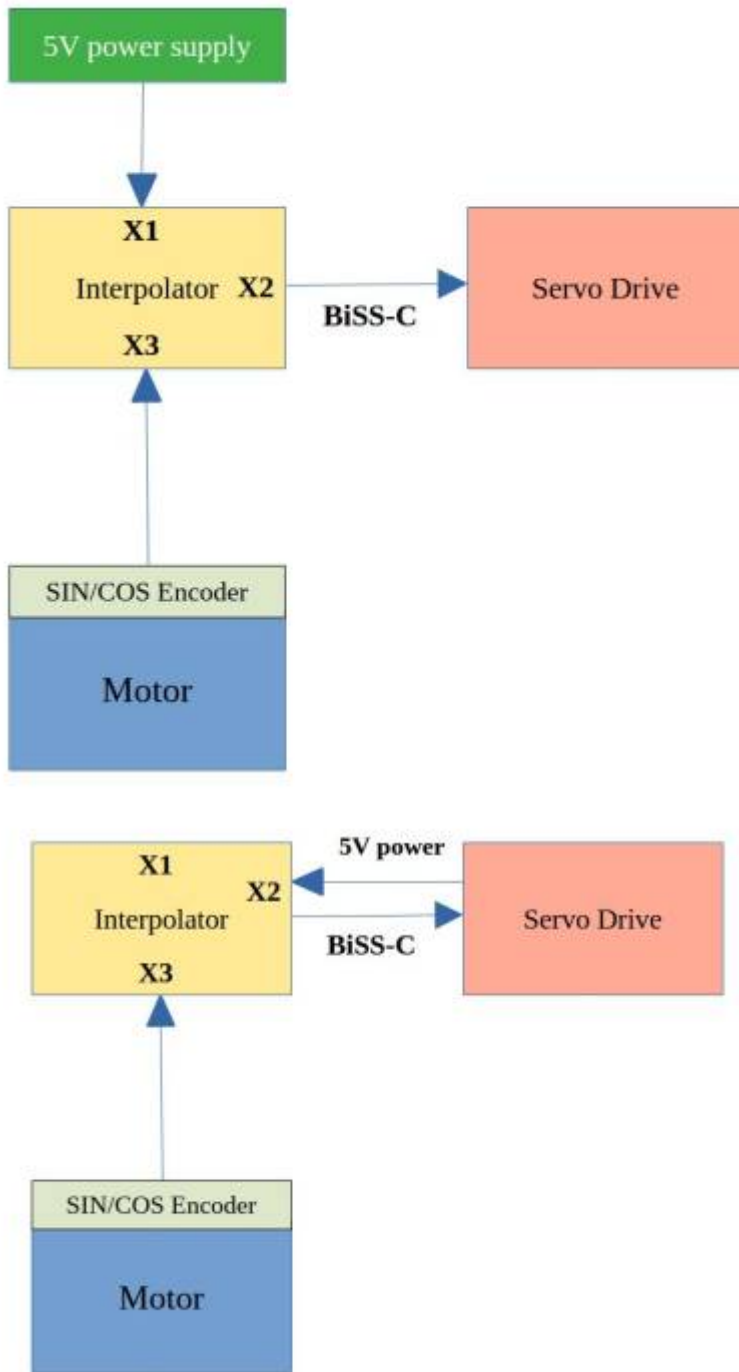

From: <https://dokuwiki.nilab.at/> - NiLAB GmbH Knowledgebase

Permanent link: [https://dokuwiki.nilab.at/doku.php?id=miniature\\_motors:interpolator](https://dokuwiki.nilab.at/doku.php?id=miniature_motors:interpolator)

Last update: 2026/06/02 13:22

