

Holding brake

Holding brake is activated when servo drive is not powered on to prevent axis from moving due to gravitational pull or other external forces by locking the motor in place. Usually used on axis mounted vertically to the ground so that the load would not drop under gravitational force when the driver is powered off or when alarm occurs.

Holding brake wiring diagram

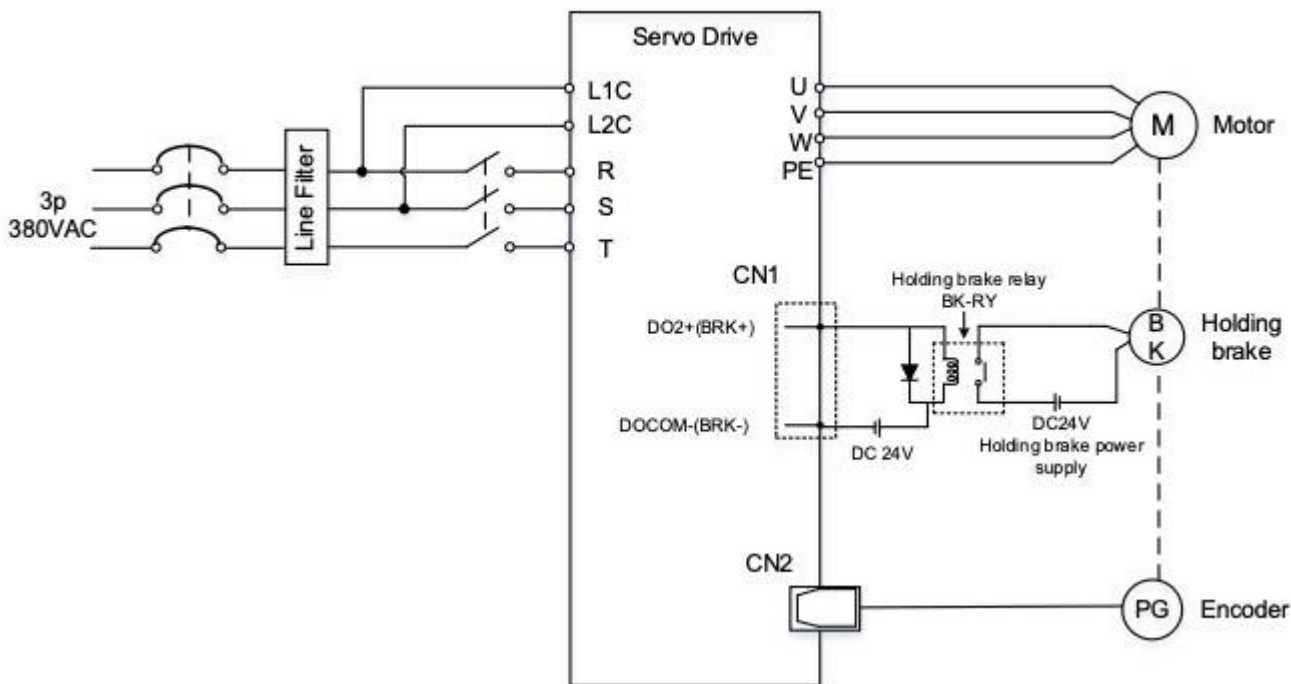
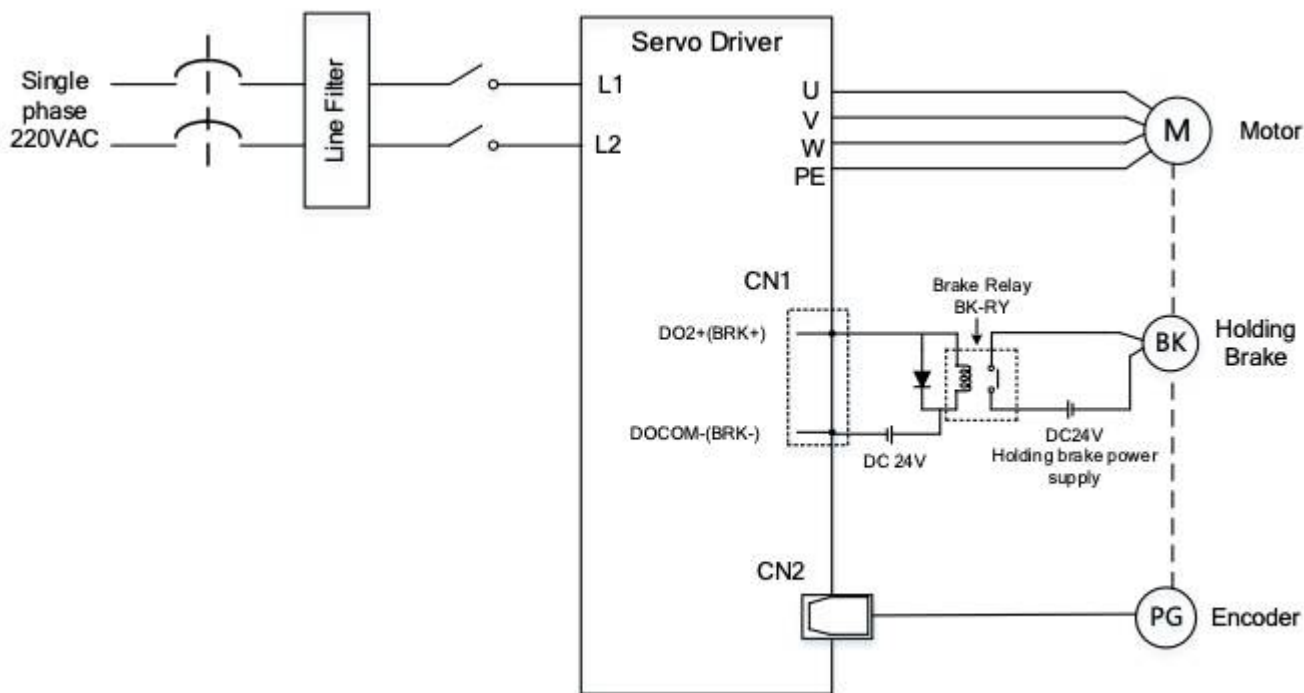

- Mechanical noise might exist when motor with holding brake is in operation but it doesn't affect the functionality of the motor.
- When the holding brake circuit is closed (holding brake deactivated), there might be magnetic flux leakage. Please be aware to not use magnetic sensor around motor with holding brake.
- 24V operating voltage for the holding brake has to be ensured to maintain the functionality of the holding brake. Please consider the voltage dropped over lengthy motor cables due to increase in cable resistance.
- it is recommended to have an isolated switching power supply for the holding brake to prevent malfunctioning of the holding brake in case of voltage drop.
- If the motor is using a magnetic encoder, holding brake wires need to be differentiated between

positive and negative terminal to prevent interference to the magnetic encoder due to wrong polarity. It might cause alarm, loss in encoder accuracy or abnormal vibration, etc. Motor with optical encoder has no such problem, so holding brake circuit can be connected in anyway.

From:
<https://dokuwiki.nilab.at/> - **NiLAB GmbH**
Knowledgebase

Permanent link:
https://dokuwiki.nilab.at/doku.php?id=n17_servo:holding_brake

Last update: **2024/03/13 06:27**

