

ULCO 132

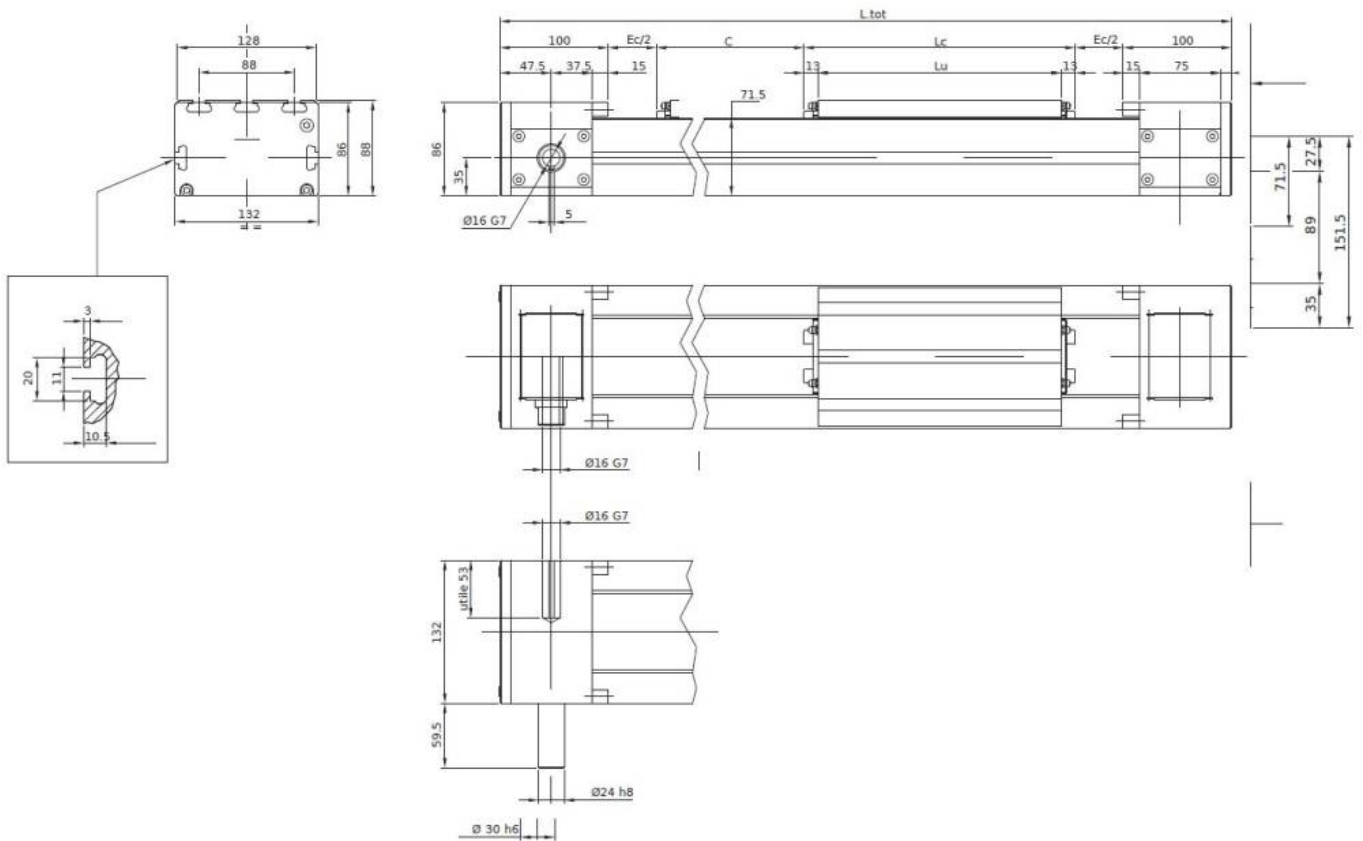

Mechanical Drawing



Load rating

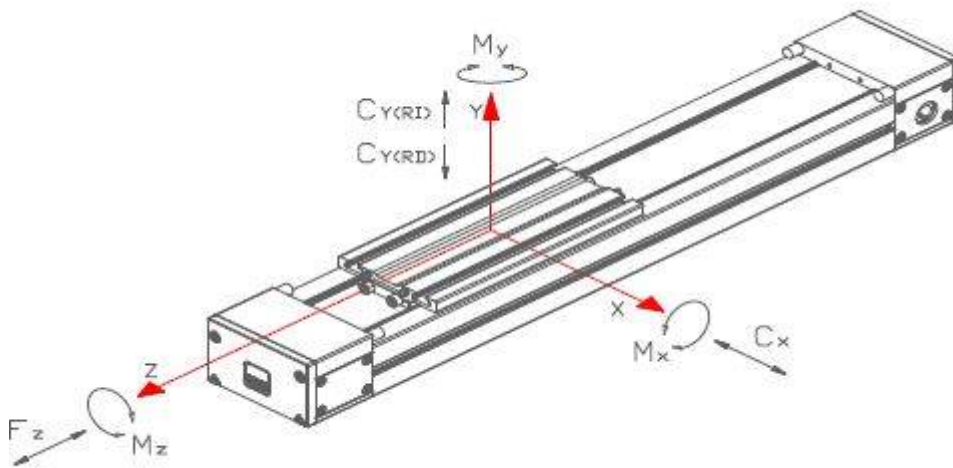

F_z [daN]	C_x [daN]	C_y [daN] (*)	C_{ox} [daN]	C_{oy} [daN] (*)	M_{ox} [daNm]	M_{oy} [daNm]	M_{oz} [daNm]
360	5053	5053 ↓ 5053 ↑	8710	8710 ↓ 8710 ↑	910	910	220

Technical data

Parameter	Symbol	Value	Unit
Max usable stroke		6500	mm
Total lenght	Ltot	C+Lc+260	mm
Carriage length	Lc	290	mm
Carriage usable length	Lu	270	mm
Extra-stroke (safety)	Ec	60	mm
Max speed		180	m/min
Max acceleration		100	m/sec ²
Position repeatability		< 0.05	mm
Aluminium profile section		132 x 71 x 5	mm
Inertia momentum of aluminium profile	Ix	1413267	mm ⁴
Inertia momentum of aluminium profile	Iy	2429437	mm ⁴
Type of mechanic		linear guide with compact block	
Belt type		Poliuretán HTD-5M-75	
Pulley teeth number		36	
Diameter		57,3	mm
Linear movement per rotation		180	mm
Operating temperature		-20 / +60	degrees

From:

<https://dokuwiki.nilab.at/> - NiLAB GmbH
Knowledgebase

Permanent link:

https://dokuwiki.nilab.at/doku.php?id=ulco:ulco_132

Last update: **2025/07/24 13:40**

